



SOLUTIONS FOR VISCOUS FLUIDS & PASTES IN ADDITIVE MANUFACTURING

From emptying the original container to degassing and tempering fluids and pastes to the 3D print head, we offer comprehensive solution concepts for your fluid management.





MATERIALS

1-COMPONENT MATERIALS

Silicones



Abrasive pastes



Waxes



Acrylates

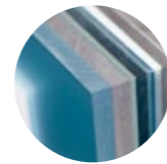

Biotechnical suspensions



High performance & technical ceramics



UV adhesives, Grease, Inks, Polyester resins, etc.

2-COMPONENT MATERIALS

Epoxy resins



Acrylates

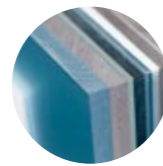

Silicones



Polyurethanes, Polyester resins, etc.



TECHNOLOGY USING THE ENDLESS PISTON PRINCIPLE

ADDED VALUE FOR THE CUSTOMER

Our tried and tested endless piston principle offers numerous advantages to the customer. Apart from the feasibility of non-component-dependent sizes, the precision of the technology is a high priority.

In addition, the endless piston principle is a technology for a wide range of product materials. Not to be disregarded is the fact that a wide range of material properties can be covered.

OUR TECHNOLOGY

Volumetric dispensing and filling systems are based on the ENDLESS PISTON PRINCIPLE and are used in low to high viscosity fluids.

At the heart of each application is a dosing pump which is purely volumetrically fed. The interaction between the rotor and the stator results in a feeding and dosing characteristic which is the same as an endlessly moving piston.

This results in a pressure-stable linear pump characteristic curve. It allows a clear statement about the ratio of revolution, time and dosed volume. Therefore, a constant volume can be dosed either via the time function or via the number of revolutions function, and give a dosing accuracy at the pump outlet of $\pm 1\%$ (depending on the material), which in practice falls below this.





1-COMPONENT PRINT HEAD WITH HEATING FUNCTION

CARTRIDGE HEATER

- Capacity of 55 ml
- Fixation with a mounting plate on the print head

CARTRIDGE ADAPTER & BLEEDING SCREW

- Easy bleeding after each cartridge replacement
- Optimum heat distribution in the print head and product material

HEATING UNIT FOR PRINT HEAD

- Heating of viscous fluids and pastes
- Heatable up to 70 °C (158 °F)

ENDLESS PISTON PRINCIPLE

- Continuous printing
- High precision printing results also for heated materials

DISPENSING NEEDLES

- Optimum heat distribution due to metal needles
- A wide range of dosing needles available

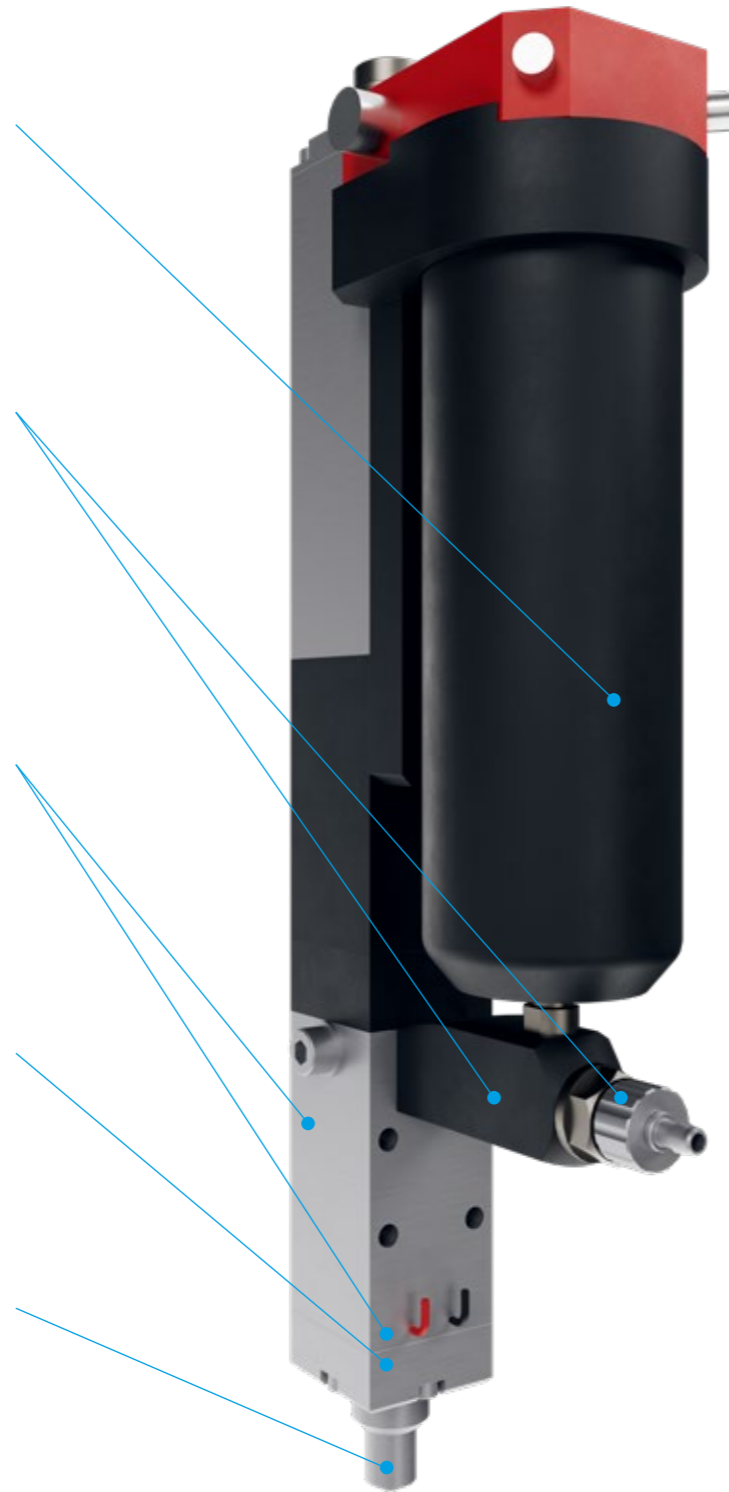

2-COMPONENT PRINT HEAD

MOTOR

- Control via stepper motor signals (24 V) or Step/Direction-Signale (3.3 V/5V)
- Compact design with parallel arrangement of the individual motors

MATERIAL SUPPLY & BLEEDING SCREW

- Easy product handling
- Optional bleeding screw for easy bleeding

ENDLESS PISTON PRINCIPLE

- Continuous printing
- For almost all viscous 2-component fluids and pastes

MONITORING & MOUNTING

- Optional monitoring via pressure sensor (material inlet and outlet)
- Different mounting opportunities to connect the print head with 3D printers

STATIC MIXER

- A wide range of different static mixers available
- Optimum mixing of 2-component fluids and pastes

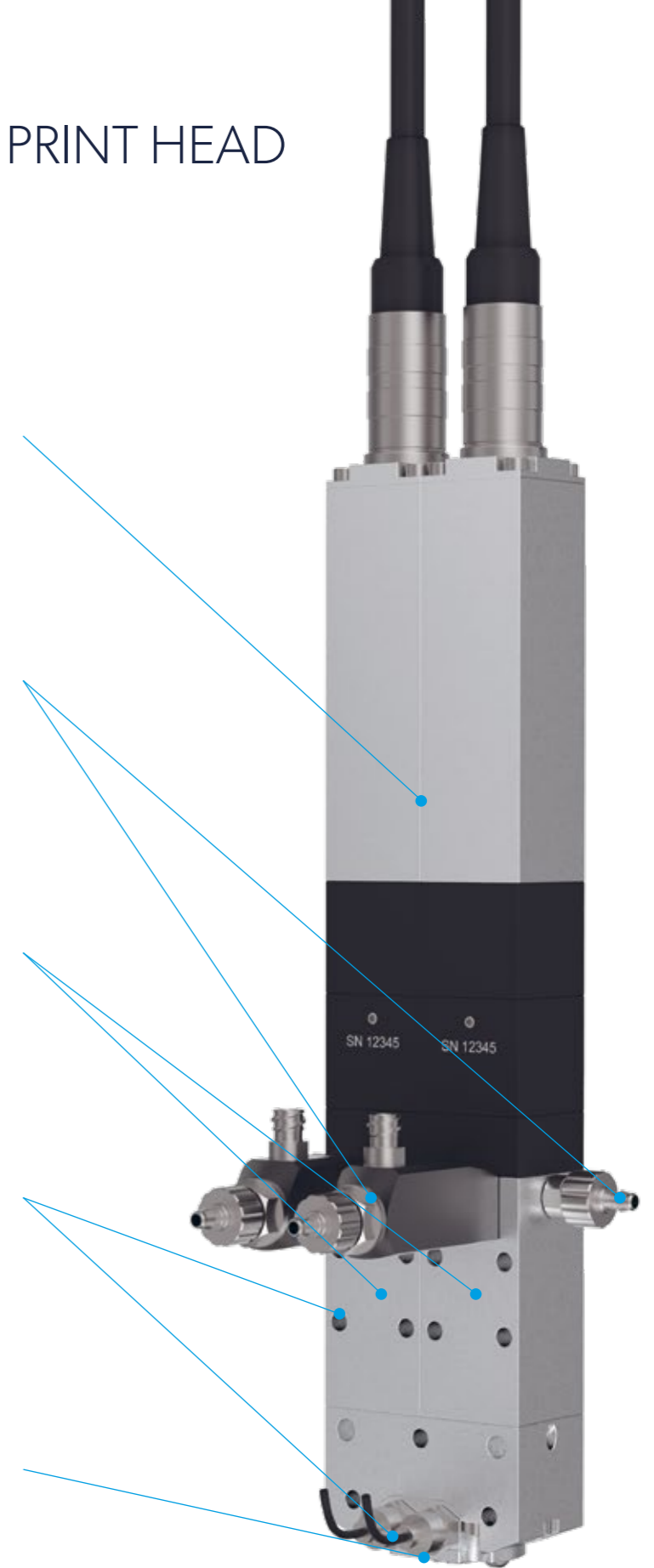



PRODUCT OVERVIEW



1-COMPONENT PRINT HEAD – VIPRO-HEAD 3

The print head impresses with its unique precision and is suitable for nearly all 1-component fluids.

Theoretical volume flow: 0.03 to 3.3 ml/min
Weight: approx. 750 g



1-COMPONENT PRINT HEAD – VIPRO-HEAD 5

The print head creates new possibilities in a wide range of applications. A consistent and accurate print result – coupled with a high printing speed – is guaranteed.

Theoretical volume flow: 0.05 to 6.0 ml/min
Weight: approx. 750 g



2-COMPONENT PRINT HEAD – VIPRO-HEAD 5/5

The fluids and pastes are conveyed volumetrically and separately from each other into the static mixer.

Theoretical volume flow: 0.05 to 6.0 ml/min per mixing head part
Weight: approx. 1,200 g



2-COMPONENT PRINT HEAD – VIPRO-HEAD 3/3

The print head allows a wide range of applications for 2-component fluids and pastes. The desired mixing ratio can be adjusted via the speed ratio of the drive units.

Theoretical volume flow: 0.03 to 3.3 ml/min per mixing head part
Weight: approx. 1,200 g



ADDITIVE DELIVERY SYSTEM – VIPRO-HEAD COLOR

This optional print head allows to add a component (e.g. color) to the printing process. The modular design facilitates integration and combination with other print heads.

Theoretical volume flow: 0.03 to 3.3 ml/min
Weight: approx. 600 g



OUR TECHNOLOGY

Volumetric dosing and filling systems are based on the [endless piston principle](#) and are used for handling low to high viscosity fluids. [Learn more!](#)



ADDITIVE DELIVERY SYSTEM VIPRO-HEAD COLOR

MOTOR

- Controlled with stepper motor signals
- Equal technology as in the 2-component printhead (modular)
- High precision enables exact control of material flow

SUPPLY OF FLUID VIA CARTRIDGE

- Color (e.g. LSR color masterbatch)
- Additive (e.g. for changing the mechanical properties)

ENDLESS PISTON PRINCIPLE

- Continuous printing
- High reliability and accuracy lead to perfect printing results

COLOR INFED INSIDE OF ADAPTER

- Perfect supply by dispensing into the center of the volume flow
- Precise supply of 1 to 3 % color into material flow
- Homogeneous color infeed leads to constant color fidelity

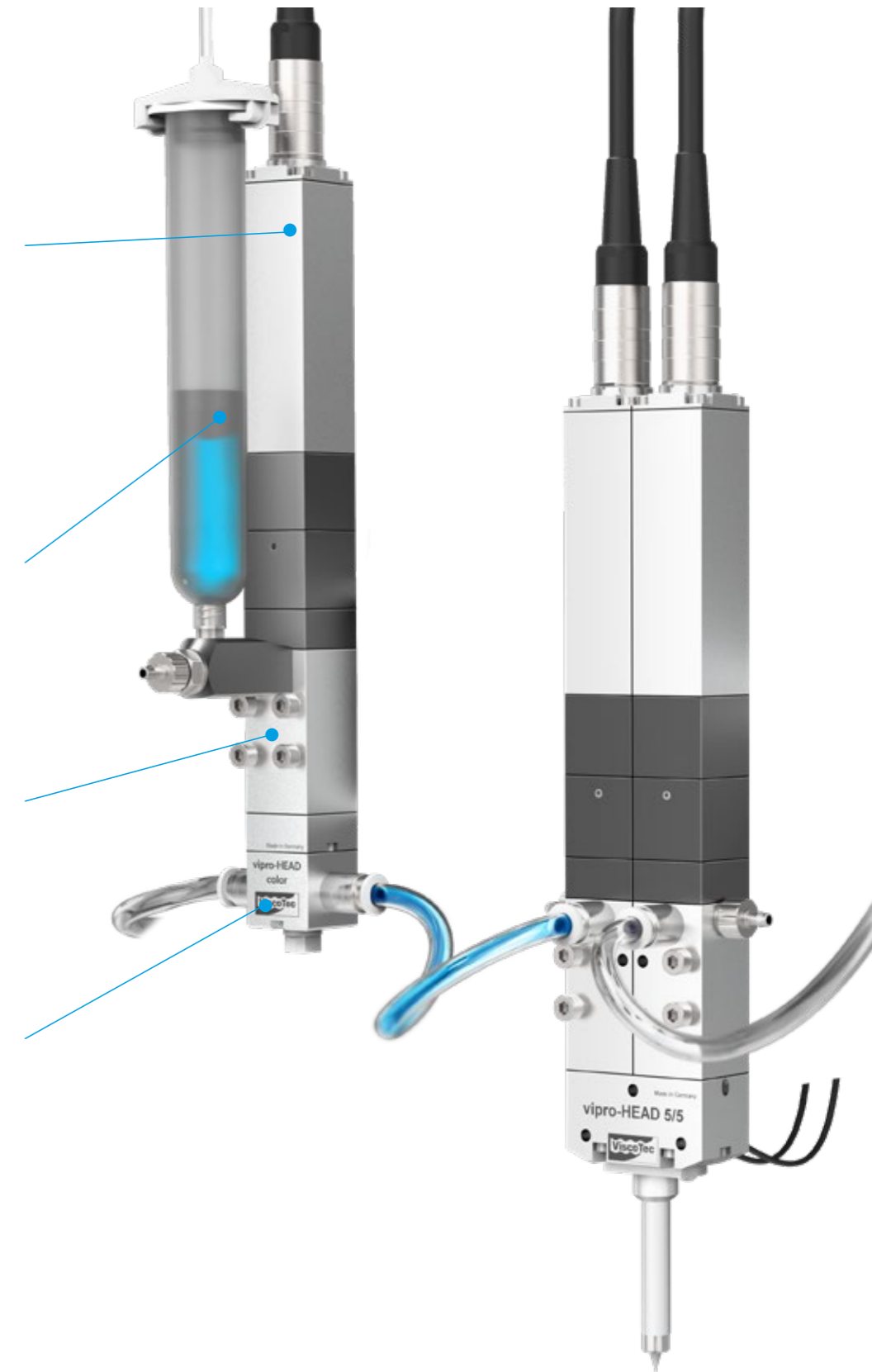



MATERIAL EMPTYING AND TREATMENT

Efficient product handling during the emptying and supplying of 1- and 2-component fluids – including intuitive control technology. Our products are specially adapted to your material to be processed and integrated into your production process.

SYSTEMS FOR MATERIAL EMPTYING

Continuous and constant material supply for seamless production without interruptions.

Container volume: 30 ml – 1,000 l
Emptying capacity: individually customizable
Viscosities: up to 7,000,000 mPas



ViscoMT-C/-CM



ViscoMT-D



vipro-FEED



ViscoMT-XS

SYSTEMS FOR MATERIAL TREATMENT

Homogeneous, air- and bubble-free pastes and fluids for a reliable dosing process – buffering and degassing dosing material.

Container sizes: 2.5 l / 3.5 l / 15 l / 25 l / 80 l
Withdrawal capacity: individually customizable
Viscosities: up to 2,000,000 mPas



ViscoTreat-Im



ViscoTreat-R



ViscoTreat-I



MODULAR SYSTEM

Based on our process know-how, your system is adapted individually to your process – including engineering and project management.

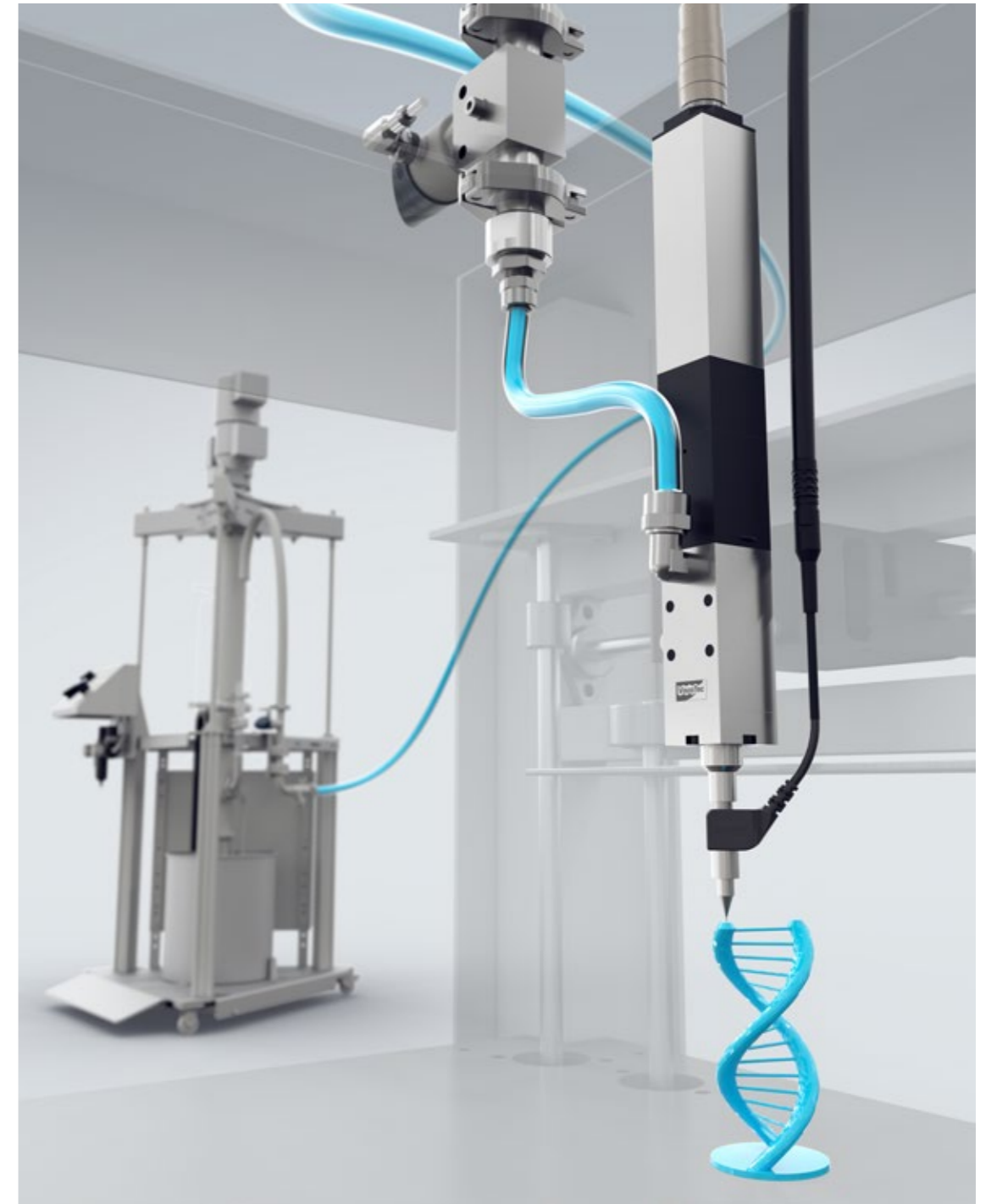

Emptying systems



Material treatment systems



3D print heads

VISCOTEC PUMPEN- U. DOSIERTECHNIK GMBH

Address: Amperstraße 13
84513 Töging a. Inn
Tel.: +49 8631 9274 0
E-mail: mail@viscotec.de
Web: www.viscotec.de

VISCOTEC AMERICA INC.

Tel.: +1 770 422 4281
E-mail: sales@viscotec-america.com
Web: www.viscotec-america.com

VISCOTEC ASIA PTE. LTD.

Tel.: +65 6569 3629
E-mail: sales@viscotec-asia.com
Web: www.viscotec-asia.com

VISCOTEC GREATER CHINA

Tel.: +86 21 6165 9002
E-mail: sales@viscotec-china.com
Web: www.viscotec.com.cn

VISCOTEC INDIA PVT. LTD.

Tel.: +91 20 4104 7135
E-mail: sales@viscotec-india.com
Web: www.viscotec-india.com

VISCOTEC FRANCE SASU

Tel.: + 33 5 56 17 64 36
E-Mail: sales@viscotec.fr
Web: www.viscotec.fr

VISCOTEC HONG KONG LIMITED

Tel.: +852 2593 1235
E-Mail: sales@viscotec-hongkong.com
Web: www.viscotec.com/hk

All data is supplied without
liability | EN 11/22

FOLLOW US

